

Chapter 9 Problem 51 †

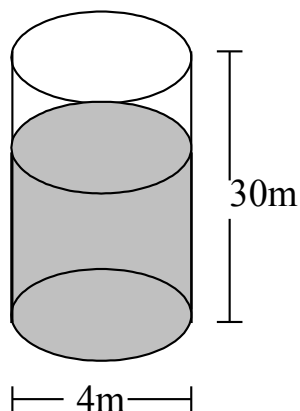

Given

$$D = 4.0 \text{ m}$$

$$h = 30 \text{ m}$$

$$m_b = 6,000 \text{ kg}$$

$$m_w = 38,000 \text{ kg}$$

$$\rho_s = 800 \text{ kg/m}^3$$

Solution

a) Find the center of mass of the silo.

Choose the origin to be the center of the base of the silo. By symmetry the center of mass will lie on the axis of the cylinder of the silo. To find the distance from the base at which the center of mass is located, use the center of mass formula. The base is located at 0 and the mass of the walls is at 15 m.

$$R = \frac{\sum m_i r_i}{M} = \frac{m_b r_b + m_w r_w}{m_b + m_w}$$

$$R = \frac{(6000 \text{ kg})(0 \text{ m}) + (38000 \text{ kg})(15 \text{ m})}{6000 \text{ kg} + 38000 \text{ kg}}$$

$$R = 13.0 \text{ m}$$

The center of the mass is 13.0 m from the base of the silo.

b) Find the center of mass of the silo when it is 2/3 filled with silage.

As above the center of mass will be located on the axis of the cylinder of the silo. Use the same formula as for part (a) except include the mass of the silage, which has a center of mass located 1/3 the height of the silo or 10 m. The mass of the silage is the volume times the density.

$$m_s = \rho V = \rho \pi \left(\frac{D}{2}\right)^2 h = (800 \text{ kg/m}^3) \pi \left(\frac{4.0 \text{ m}}{2}\right)^2 (20 \text{ m}) = 201,000 \text{ kg}$$

Now the center of mass is

$$R = \frac{\sum m_i r_i}{M} = \frac{m_b r_b + m_w r_w + m_s r_s}{m_b + m_w + m_s}$$

†Problem from Essential University Physics, Wolfson

$$R = \frac{(6000 \text{ kg})(0 \text{ m}) + (38000 \text{ kg})(15 \text{ m}) + (201,000 \text{ kg})(10 \text{ m})}{6000 \text{ kg} + 38000 \text{ kg} + 201,000 \text{ kg}}$$

$$R = 10.5 \text{ m}$$

The center of mass is 10.5 m from the base of the silo.